



ZARACCOM LENSES

Foldable Multifocal Intraocular Lens Instruction For Use Zaraccomm A100



DESCRIPTION: Zaraccomm foldable multifocal intraocular lenses (IOLs) are designed for cataract surgery as an optic device to replace the crystalline lens in the human eye. Foldable IOLs consist of hydrophobic acrylic and are manufactured with bonded UV-absorber, are sterile, 1-piece and suitable for posterior chamber implantation.

Zaraccomm multifocal foldable acrylic one-piece IOL incorporates a 360-degree squared edge designed. The lens is designed to increase the spectacle independency for both distance and near vision. This lens has a diffractive multifocal surface on the posterior side of the lens. The labeled power of the lens is the distance power. The near power represents a +3.5 diopter add in actual lens power.

MATERIAL DESCRIPTION: The foldable hydrophobic acrylic IOLs, referred to as acrylic origin chemical structure which consists of 80% oligo urethane acrylate with phenoxyethyl methacrylate, octyl methacrylate, methacrylic acid and benzotriazole.

Table1. Physical Characteristic of IOLs

Physical Characteristic	Description
Models	A100
Material	Hydrophobic Acrylic (Acrylate-Methacrylate Copolymer)
Index of Refraction	1.51
Optical Design	Diffractive plano convex, 360° Square Edge
Near add	+3.5
YAG Laser	Stable
Sterilization Type	Ethylene Oxide
Power	+10.0 through +25.0 Dpt (0.50 Dpt increments)
Estimated A. Constant (Calculated theoretically)	117
Haptic Angle	0°
Haptic Configuration	Modified L-Loop
Water Content	<1%

Figure 1: Design of Zaraccomm Multifocal IOL Model

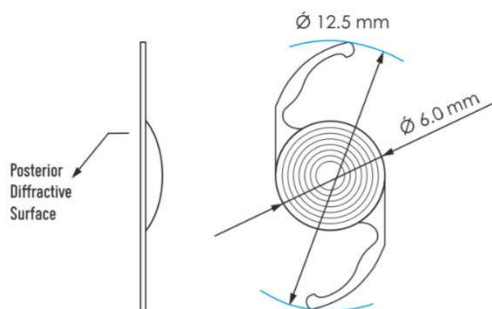

BIOCOMPATIBILITY TESTING

Potential patient safety risks to the material(s) of this device were evaluated through nonclinical physicochemical characterization and biocompatibility testing in accordance with international standards applicable to IOL devices. Nonclinical testing demonstrated no safety concerns for local or systemic toxicity, that the IOL material was physically and optically stable, and that there were no leachable substances arising from the manufacturing process (including sterilization) or device material(s) that posed a safety risk. The device possesses an acceptable patient safety profile when used in accordance with the Instruction for Use (IFU) for its intended clinical purpose as an ocular implant device.

MODE OF ACTION

Intraocular lens implantation is called a routine practice in the literature, since its optical advantages and complications are very low. Small incision cataract surgery technique has been developed to reduce post-operative astigmatism and patient rehabilitation time. These lenses are used by a trained ophthalmic surgeon and placed in the posterior chamber of the eye instead of the natural crystalline lens. In this position, the lens corrects vision by functioning as a refractive medium in aphakia correction. For bifocal the posterior plano diffractive optic contains an additional power of 3.5 Diopter to support Near vision. Achieving the device's intended mode of action is achieved by cataract surgery with the implantation of an artificial lens instead of the natural lens of the eye.

Product user group : Ophthalmologists

Patient population : Adult aphakia patients

INTENDED USE

ZARACCOM multifocal intraocular lenses are intended for use by a trained ophthalmic surgeon, for the treatment of aphakia in adult patients and in patients who have had their lenses removed by phacoemulsification with cataracts. It is intended for patients who need near and distance vision and who desire an independent field of vision from spectacle. These lenses are intended for placement in the capsular bag.

INDICATIONS

Zaracomm multifocal IOLs are indicated for primary implantation for the visual correction of aphakia in adult patients in whom a cataractous lens has been removed.

CONTRAINDICATIONS

To date there are no absolute contraindications to Intraocular Lenses implantation. There are no known contraindications with the use of Zaracomm IOL when used as recommended.

RESIDUAL RISKS AND UNDESIRABLE EFFECTS

As with any surgery, there is risk involved whether or not an IOL is implanted. Potential complications accompanying cataract or implant surgery are not limited to the complications listed below. Cataract surgery, with or without lens implantation might be associated with:

- Ocular inflammation
- Hemorrhage
- Intraocular pressure elevation
- Post-operative infection

- Retinal breaks and detachment
- Cystoid macular edema
- Corneal edema
- Posterior capsule opacity

Complications related with Intraocular Lens implantation:

- Capsular rupture
- Vitreous loss
- Lens decentration and luxation
- Wrong calculation of IOL power
- Damage of IOL during implantation

WARNINGS AND PRECAUTIONS

- A high level of surgical skill is required for intraocular lens implantation. The surgeon should have observed and/or assisted in numerous implantations and successfully completed one or more courses on intraocular lens implantation before attempting to implant intraocular lenses.
- Prior to surgery, prospective patients should be informed of the possible risks and benefits associated with this IOL as well as the risks and benefits associated with cataract surgery. After surgery, physicians should provide an information brochure to patients regarding the IOL implanted (located at www.anadolutip.com.tr) along with the implant card.
- Do not use the intraocular lens in case the sterile package was opened or damaged or in any case of doubt.
- Do not use the intraocular lens after expiration date.
- Do not resterilize this intraocular lens by any method.
- Do not reuse the lens. Single use only. The lens must be used once only for a single patient. Reuse of this single-use device may result in serious injury, such as endophthalmitis.
- Do not store at under 5°C (41°F) and above 35°C (95°F). The manufacturer recommends the storage and usage of lenses at room temperature (This allows the intraocular lens to open more slowly in the capsule). Do not expose the lens to sunlight.
- Do not soak the lens in solutions other than balanced saline solutions or equivalents.
- This lens is used safely with viscoelastic materials (OVD). As a manufacturer, it is recommended to use an OVD with a density of 1.4% / 1.6% / 1.8%.
- Handle the lens carefully to avoid damage to lens surfaces or haptics.
- Do not attempt to reshape haptics in any way.
- After implantation the position of haptics must be placed opposite of clockwise.
- Recent contact lens usage may affect the patient's refraction; therefore, in contact lens wearers, surgeons should establish corneal stability without contact lenses prior to determining IOL power.
- The long-term effects of intraocular lens implantation have not been determined. Therefore, physicians should continue to monitor patients postoperatively on a regular basis.
- Zaracom intraocular lenses are posterior chamber lenses. The safety and effectiveness of a posterior chamber lens, if placed in the anterior chamber, has not been established.
- It is recommended that OVD be removed from the eye at the close of surgery with emphasis on the space between the posterior capsule and lens. This may be accomplished by gently

depressing the IOL optic posteriorly with the irrigation/aspiration (I/A) tip while using standard I/A techniques to remove the OVD from the eye. This should force any trapped OVD anteriorly where it can be easily aspirated.

SUGGESTED A-CONSTANT

The suggested A-constant indicated on the outer label is presented as a guideline and is a starting point for implant power calculations. It is recommended that you develop your own constant appropriate for you based on clinical experience with the particular lens models, surgical techniques, measuring equipment, and postoperative results.

If additional information on lens power calculation is needed, please contact with the manufacturer. The contact data are given at manufacturer details.

CALCULATION OF LENS POWER

Accurate biometry is essential for successful visual outcomes. Preoperative calculation of required lens power for these posterior chamber intraocular lenses should be determined by the surgeon's experience, preference, and intended lens placement. A reference A-Constant value is located on the outer label. Lens power calculation methods are described in the following references:

Hoffer, K.J. The Hoffer Q Formula: A Comparison of Theoretic and Regression Formulas. J. Cataract Refract. Surg. 19:700-712, 1993.

Holladay, J.T., et al. A Three-part system for Refining Intraocular Lens Power Calculations. J. Cataract Refract. Surg. 14:17-24, 1988.

Holladay, J.T., et al. Standardizing Constants for Ultrasonic Biometry, Keratometry, and IOL Power Calculations. J. Cataract Refract. Surg. 23:1356-1370, 1997.

Retzlaff, J.A., Sanders, D.R., and Kraff, M. Lens Implant Power Calculation, 3rd ed., Slack, Inc., Thorofare, N.J., 1990.

HaigisW: The Haigis Formula, In: Intraocular lens power calculatios. H. John Sammas (eds)Slack Incorporated, Thorofare NJ, USA, pp 39-57, 2004

INSTRUCTIONS FOR USE

1. Prior to implanting, examine the lens package for proper lens model, dioptric power, and expiration date.
2. Open the package and remove the lens in a sterile environment. The lens is provided in a sterile plastic container. To remove the lens, internal box cover is slowly pulled backward as shown by the arrow direction. The protective cover lifts and the lens is taken out of the internal box with forceps. The lens is placed in the proper position for the implantation. The lens must be taken and implanted carefully, in order not to scratch the optic surface by an instrument.
3. Rinse the lens thoroughly using sterile balanced salt solution.
4. To minimize the occurrence of marks on the lens due to folding, all instrumentation has to be scrupulously clean. The manufacturer recommends using forceps with round edges and smooth surfaces.
5. Handle the IOL by the haptics only when removing the lens from the case. DO NOT grasp the optical area with forceps.
6. The lenses are carefully checked and inspected by manufacturer to assure a high-quality product. The lenses are to be studied carefully under surgical operation microscope before

implantation. If a defect or deformation is noted or suspected, the lens should be returned to the manufacturer.

7. Implantation has to be performed on aphakic adult patients by a trained ophthalmic surgeon.
8. After placing the lens in the capsular bag, rotate the lens 90 to 180 degree in order to better centralization.
9. Implant the IOL with the most appropriate surgical procedure for the patient. Surgeons should verify that appropriate instrumentation is available prior to surgery. Refer to **ANY OTHER DEVICES AND PRODUCTS WHICH ARE INTENDED TO BE USED IN COMBINATION WITH THE DEVICE** for qualified of compatible products.

ANY OTHER DEVICES AND PRODUCTS WHICH ARE INTENDED TO BE USED IN COMBINATION WITH THE DEVICE

The foldable lenses can be folded by various folding forceps designed for foldable lenses and it can be implanted also by implantation forceps and cartridge-injector systems. Posterior chamber lenses are designed for implantation in the capsular bag by injector method with a minimum incision size of 2.2 mm. It is recommended to use cartridge systems that validated and approved by manufacturer. The use of an unqualified combination may cause damage to the lens and potential complications during the implantation process (e.g., IOL decentration, tilt, or dislocation, spatial distortions, visual disturbances, or decreased/blurred vision). In addition, if the instructions for use are not followed and/or used by persons other than a trained ophthalmic surgeon, "Abnormal Use" will occur, and the following hazardous situations may be encountered. Although this situation has no effect on the patient, it causes the intraocular lens not to be used in the operation.

Abnormal Use Cases;

- The intraocular lens gets stuck in the cartridge injector system,
- Haptic rupture, breakage,
- Scratches, cracks on the optical surface,
- Uncontrolled protrusion of the intraocular lens from the injector.

Qualified cartridge injector systems that can be used with Zaracom foldable IOLs are listed at IFU ANNEX document.

PATIENT IMPLANT CARD

The Patient Lens Implant Card included in the package is to be completed and given to the patient, together with instructions to keep the card as a permanent record to be shown to any eye care practitioner that the patient consults in the future.

To fill out the patient implant card:

1. To adhere it on the implant card, remove the product label from the box and adhere it to the place indicated on the implant card.
2. Fill out the following information on the implant card:

Date of surgery, Eye implanted [mark left (L) or right (R)], Patient name, Surgeon name, and Hospital or health institution name and address.

A copy of the patient information brochure is available at www.anadolutip.com.tr. Print a copy of the patient information brochure. Place a sticker one of the same labels to the patient information brochure before giving it to the patient.

In the EU, it is a requirement that the patient be given a completed implant card along with the patient information brochure.

MAGNETIC RESONANCE COMPATIBILITY

Zaraccomm foldable hydrophobic IOL is magnetic resonance (MR) Safe. The IOL consists of acrylate/methacrylate copolymer material, which is a non-conducting, non-metallic, non-magnetic material that poses no known hazards in all magnetic resonance imaging environments.

LIFETIME OF THE IOL

Based upon material characterization of the Zaraccomm IOL material, the IOL is expected to be stable indefinitely over the lifetime of the patient.

PACKAGING AND EXPIRATION DATE

Zaraccomm lenses are supplied in dry, in a double sterile package terminally sterilized with ethylene oxide, and must be opened only under aseptic conditions. The packaging sterility is guaranteed until expiry date except in case of damaging or opening of the package. The use-by date is clearly indicated on the outer box label of the carton. Any intraocular lens held after the use-by date should be returned to Anadolu Tıp Teknolojileri A.Ş.

DISPOSAL

Discarded IOLs and Cartridge Injector System / Preloaded Systems (used or unused (if opened from sterile packaging)) are classified as a potential source of infection or microbial hazard and should be disposed of as medical (clinical) waste according to regulatory practices.

LIABILITY

The manufacturer's liability covers the design and production of these intraocular lenses; it shall be incurred in no way in case of accidents resulting of the use of these lenses.

SERIOUS INCIDENT REPORTING

Any serious incident that may reasonably be regarded as device related should be reported to;

Anadolu Tıp Teknolojileri A.Ş.

By Phone: +90 346 2181418

By Email: mail@anadolutip.com.tr

Website: <http://www.anadolutip.com.tr>

Each IOL is identified by a serial number which provides traceability, and this information should be given to Anadolu Tıp Teknolojileri A.Ş.

NOTE: In Europe, these serious incidents must also be reported to the competent authority for medical devices of the appropriate State.

CLINICAL BENEFITS of ZARACCOM IOLs

Clinical evidence from published peer-reviewed clinical literature, clinical experience, and clinical investigations establishes an acceptable safety and performance profile for Zaraccomm foldable hydrophobic IOL. The Zaraccomm IOL was designed for visual correction of aphakia in adult patients following cataract surgery and has the following potential benefit:

ZARACCOM FOLDABLE HYDROPHOBIC ACRYLIC POSTERIOR CHAMBER LENS CLINICAL STUDIES

Two clinical studies have been performed on Zaraccomm Foldable Posterior Chamber Lenses. These are summarized below.

1. EVALUATION OF EFFICACY AND SAFETY OF ZARACCOM F260 INTRAOCULAR LENSES IN CATARACT TREATMENT: A National, Multicenter, Prospective Clinical Device Study Including Historical Control Group

Totally, 363 patients (females 49.03%, males 50.97%) were analyzed and the mean age was 67.11±10.19.

Efficacy Results:

Compared to pre-operative values, visual acuity was significantly improved at post-operative 1st-2nd days, 7th-14th days, 30th-60th days, 120th-180th days and 330th-420th days (p<0.001 for each). In the comparison of VA rates between the patients with and without pre-operative ocular pathology, statistically significant difference was observed between groups on the post-operative 1st-2nd days (p<0.001), 7th-14th days (p<0.001) and 30th-60th days (p=0.002). Total numbers of patients who had insufficient visual acuity were 95 on postoperative 1st-2nd days, 35 on post-operative 7th-14th days, 15 on post-operative 30th-60th days, 19 on post-operative 120th-180th days and 9 on post-operative 330th-420th days. There was an improvement in visual acuity with time.

Table2. Best Corrected Visual Acuity in the Best Case Patient Population at a Minimum of One Year Postoperatively, Zaraccom F260

Age (year)	1 st -2 nd days		7 th -14 th days		30 th -60 th days		120 th -180 th days		330 th -420 th days	
	n/N	%	n/N	%	n/N	%	n/N	%	n/N	%
<=50	19/22	86.4	19/19	100.0	20/20	100.0	19/19	100.0	20/21	95.2
51-60	53/65	81.5	52/55	94.5	41/43	95.3	58/59	98.3	61/61	100.0
61-70	89/132	67.4	107/115	93.0	103/109	94.5	106/115	92.2	126/130	96.9
71-80	77/119	64.7	89/104	85.6	81/85	95.3	94/102	92.2	114/119	95.8
81+	9/21	42.9	15/20	75.0	13/17	76.5	14/16	87.5	14/15	93.3
Total	247/359	68.8	282/313	90.1	258/274	94.2	291/311	93.6	335/346	96.8

Safety Results:

Safety was evaluated according to cumulative and persistent adverse events rates specified in ISO 11979-7:2006. Cumulative adverse events are those which occurred at any time during the subjects' postoperative follow-up. Totally, 1 secondary surgery interventions (0.28%) was present throughout the study. Persistent adverse events are those which are present at postoperative 330th-420th days. No persistent adverse events were observed in the study.

Table3. Cumulative Adverse Events at a Minimum of One Year Postoperatively Zaraccom F260

	N (=363)	%
Cumulative secondary surgery intervention	1	0.28*
Occurrence time of adverse event		
Post-operative 1 st -2 nd days (N=363)	1	0.28
Age groups		
61-70	1	0.28
Centers		
Center No 2	1	0.28
Total	363	100.00

*Difference is not statistically significant when it is compared with FDA grid (0.8%) (X²=1.12, p=0.291).

2. EVALUATION OF EFFICACY AND SAFETY OF ZARACCOM UF60125 INTRAOCULAR LENSES IN CATARACT TREATMENT: A National, Single-center, Prospective Clinical Device Study Including Historical Control Group

Totally, 98 patients (females 40.8%, males 59.2%) were analyzed and the mean age was 64.5±12.9 years.

Efficacy Results:

The number of patients who had sufficient visual acuity were 67 (70.5%) on post-operative 1st-2nd days, 88 (91.7%) on post-operative 7th-14th days, 90 (93.8%) on post-operative 30th-60th days, 90 (94.7) on post-operative 120th-180th days and 90 (95.8%) on post-operative 330th- 420th days. There was an improvement in visual acuity with time.

Table4. Best Corrected Visual Acuity in the Best Case Patient Population at a Minimum of One Year Postoperatively, Zaraccomm UF60125

Age	Before operation		1 st -2 nd days		7 th -14 th days		30 th -60 th days		120 th -180 th days		330 th -420 th days	
	n/N	(%)	n/N	(%)	n/N	(%)	n/N	(%)	n/N	(%)	n/N	(%)
<=50	5/13	38.5	11/12	91.7	13/13	100.0	13/13	100.0	13/13	100.0	13/13	100.0
51-60	4/19	21.1	15/20	75.0	16/20	80.0	17/20	85.0	18/20	90.0	19/20	95.0
61-70	10/24	41.7	19/25	76.0	25/25	100.0	25/25	100.0	25/25	100.0	25/25	100.0
71-80	8/29	27.6	18/30	60.0	27/30	90.0	28/30	93.3	28/30	93.3	28/30	93.3
81+	1/7	14.6	4/8	50.0	7/8	87.5	7/8	87.5	6/7	85.7	7/8	87.5
Total	28/92	30.4	67/95	70.5	88/96	91.7	90/96	93.8	90/95	94.7	92/96	95.8

Safety Results:

Safety was evaluated according to the cumulative and persistent adverse events rates specified in ISO 11979-7:2006. No cumulative or persistent adverse events were observed in the study.

















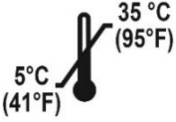

General Safety Data:

The reported studies and publications found provide evidence that medical devices with a high similarity to the Zaraccomm IOL are safe for use. It shall be noted that complications may occur due to the surgical intervention as a matter of fact or if the device not being used according to the IFU. For safety data, only inflammatory findings have been reported in intraocular lenses as a post-operative pathology. As an adverse event, only one patient had secondary surgery interventions.

SUMMARY OF SAFETY AND CLINICAL PERFORMANCE (SSCP)

Additional information about IOLs can be found in a document called “Summary of safety and clinical performance” or SSCP and associated with the device's basic UDI. Once the website is live, this document will be available at <https://ec.europa.eu/tools/eudamed>.

SYMBOLS USED ON LABELING

SYMBOL	EXPLANATION	SYMBOL	EXPLANATION
	Catalogue number		Serial Number
	Unique device identifier		Date of manufacture
	Double sterile barrier system		Medical Device
	Sterilized using ethylene oxide		Use by date
	Temperature limit: lower temperature limit is 5°C (41°F) and upper temperature limit is 35°C (95°F)		The product conforms to European Medical Device Regulation 2017/745 and meets applicable health, safety and environmental requirements. If the mark is accompanied by a number, conformity is verified by the indicated notified body
	Do not re-sterilize		Keep away from sunlight
	Do not re-use		Do not use if package is damaged and consult instructions for use
	Manufacturer		Consult instructions for use or consult electronic instructions for use
	Model number		Keep dry



ANADOLU TIP TEKNOLOJİLERİ ÜRETİM PAZARLAMA İTHALAT İHRACAT TİCARET VE SANAYİ ANONİM ŞİRKETİ

1.Organize Sanayi Bölgesi 2. Kısım 5. Cad. No:10 Merkez, Sivas, Türkiye

Tel. +90 346 218 14 18 (pbx)

Fax.+90 346 218 14 20

www.anadolutip.com.tr

info@anadolutip.com.tr



IFU ANNEX Document

Suitable cartridge and injector systems are as below;

Product	: Top Loaded Cartridge Injector System
Manufacturer	: ODC Inc. / FRANCE
Model	: Ergotouch FLY 2.2 and Ergotouch FLY 2.4
Recommended power range for Ergotouch FLY 2.2	: Up to 25,00 Dpt Zaracom IOLs
Recommended power range for Ergotouch FLY 2.4	: Over 25,00 Dpt Zaracom IOLs

The instructions for use are summarized, please refer to the device's own IFU for detailed information.

Top Loaded Cartridge Injector System Instruction for Use

1. Open the blister pack using standard sterile procedures. Place contents onto a sterile field.
2. Fill the cartridge tunnel of the **Top Loaded Cartridge Injector System** and the loading chamber of the cartridge sufficiently with validated viscoelastic solution. Balanced salt solution should not be used as the sole lubricant.
3. Place the lens symmetrically on the central hinge of the open cartridge. Asymmetric insertion of the lens can lead to rotation of the lens in the injector.
4. Press the lens into both guide rails with rounded sterile tweezers and gently move the lens back and forth horizontally in order to ensure that it can move freely.
5. Ensure that the lens is correctly aligned and make sure that neither the edge of the lens nor the haptic are wedged in.
6. Press the sides of the cartridge together until the click-lock mechanism engages. The audible click demonstrates the correct closure of the cartridge. A final visual check is recommended after closure to ensure haptic is not trapped.
7. Insert the cartridge into the front end of the injector. Push the cartridge to the very front position.
8. Carefully push the plunger forward and ensure that the silicone tip correctly enters the loading chamber. If the silicone tip cannot be introduced into the loading chamber, retract the plunger to the starting position and align the silicone tip straight, using sterile tweezers. Continue to push the cushion until the inner spring begins to press together. Pull the plunger back a few millimeters and then push it forward again. This step ensures that the lens is correctly grasped.
9. In order to avoid excess viscoelastic entering the eye, gently push the plunger until the lens is at the front of the cartridge, releasing the excess viscoelastic well away from the eye before inserting the injector into the incision.
10. Guide the tip of the cartridge through the incision and push it across the iris to the near edge of the pupil.
11. Slowly press the plunger forward to support the correct delivery of the lens into the eye and simultaneously withdraw the instrument from the eye. To avoid swelling of the silicone tip during ejection from the cartridge, only push the plunger until the lens has emerged completely.
12. Position the lens carefully and if necessary rotate it with the aid of the appropriate positioning hook.
13. Remove the viscoelastic material from the eye and the lens, with standard irrigation and aspiration techniques.

Product	: Back Loaded Cartridge Injector System
Manufacturer	: AST Products Inc. / USA
Model	: BIOLI-D, BIOLI-C
Recommended power range for BIOLI-C	: Up to 25.00 Dpt Zaracom IOLs
Recommended power range for BIOLI-D	: Over 25.00 Dpt Zaracom IOLs

The instructions for use are summarized, please refer to the device's own IFU for detailed information.

Back Loaded Cartridge Injector System Instruction for Use

1. Inspect the blister packaging for any damage. If damage is observed or suspected, use another injector set. Open the blister packaging using standard sterile procedures and transfer the injector and cartridge to the sterile field.
2. Apply viscoelastic solution to the Back Loaded Cartridge Injector System. Ensure that viscoelastic solution is at operating room temperature before filling the cartridge, immediately prior to loading and delivery of the lens.
3. Using holding forceps, grasp the lens by the optic edge and gently place the lens anterior side up into the rear of the cartridge. The lens should be inserted until the optic is a little more than half-way inside the cartridge. Use the holding forceps to gently push down on the lens. Verifying that the lens is on the bottom surface of the cartridge.
4. Using holding forceps, grasp the trailing haptic, and gently fold the haptic onto the anterior side of the optic.
5. Slowly push the optic edge to position the lens as far into the cartridge as the forceps will permit, while ensuring the lens remains on the bottom surface of the cartridge and the trailing haptic remains on top of the optic.
6. Be careful not to scratch the IOL during this process. Remove the forceps after pushing the lens, and immediately.
7. Insert the cartridge into the handpiece by sliding the cartridge backward into the handpiece slot.
8. Advance the plunger in one slow motion. The plunger should make initial contact with the cartridge at the ramp.
9. Slowly push the plunger forward to advance and fold the optic. Verify that the lens moves forward at the same rate as the plunger.
10. Continue to push the plunger slowly until the spring engages. Slightly pull back the plunger about 1 mm before continuing to push the plunger until the lens has been safely delivered.
11. As the lens moves through the cartridge, verify that the plunger tip is behind the optic and the leading haptic is looped in front of the optic. The leading haptic should become looped back between the folded halves of the optic. If the leading haptic is not looped back, retract the plunger and reload the lens again.
12. Insert the tip of the cartridge through the incision. Position the tip at the anterior capsule opening. Advance the lens only until the optic exits the nozzle.
13. Withdraw the cartridge nozzle once the lens has exited the cartridge nozzle.
14. Place and center the lens using a suitable positioning instrument.
15. Discard the injector and cartridge accordingly.

Precautions

- The **Top/Back Loaded Cartridge Injector System** should be used by trained and qualified professionals only. The result of surgical procedure depends on skill and abilities used with the device and other products during the surgery
- This product is supplied sterile and should not be used if inner packaging is soaked, opened or damaged
- All contents are for single use and should never be re-sterilized
- Do not use the cartridge if tip has been broken or damaged
- Always use viscoelastic when loading the foldable intraocular lens into the cartridge. The lens should be injected immediately after being introduced into the cartridge as viscoelastic solution may lose its lubricating properties when exposed to air for a long period of time
- Please follow up carefully the loading instructions
- In case the device falls on the floor or touch any other unsterile product, discard it according to standard rules for residues in health establishments

If the above precautions are not followed, foreseeable risks or complications could cause:

- Improper handling, loading and use of the injector can cause damage to the lens and patient such as tissue damage, inflammation, contamination
- Contamination during use could generate infection / contamination of the patient
- Re-use of the Single-use Injector and/or cartridge could generate contamination between patients
- There are risks such as the intraocular lens getting stuck in the cartridge injector system, haptic breakage, scratches and cracks on the optical surface, uncontrolled removal of the intraocular lens from the injector.